

THIS IS A C.A.D. GENERATED DRAWING
DO NOT MAKE MANUAL REVISIONS TO MASTER.

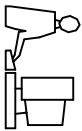

* UNLESS OTHERWISE SPECIFIED TOLERANCES
ON DECIMAL IS:

UNIT: MM
DIM TOL
X ±0.75
XX ±0.20
XXX ±0.10

ISSUE NUMBER
ORIGINAL ①
DRAWING REDRAWN, NOTES &
TOLERANCES UPDATED
N.SONDH NOV. 25/16②

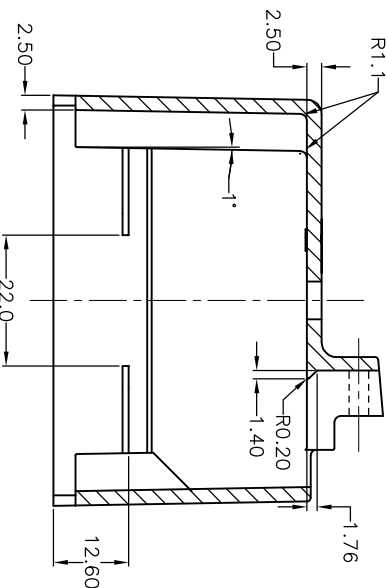
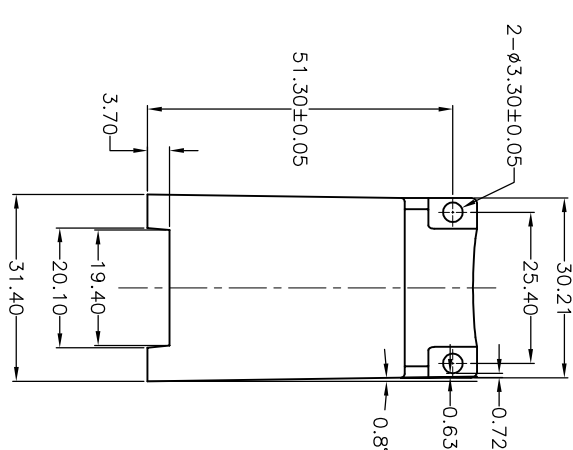
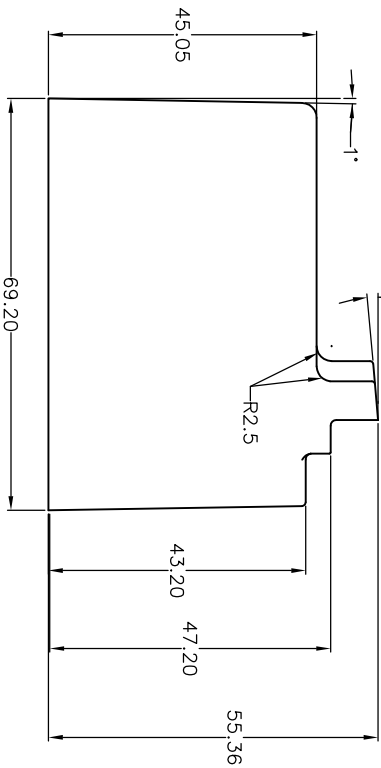
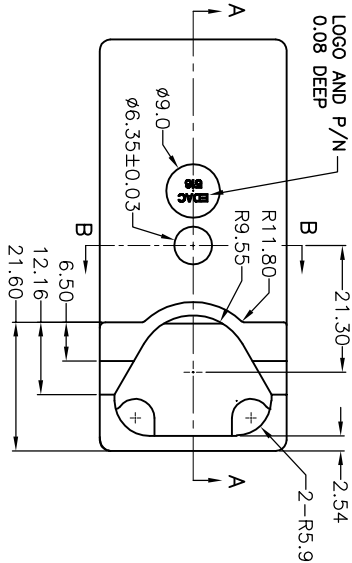

SECTION A-A
SCALE 1:1

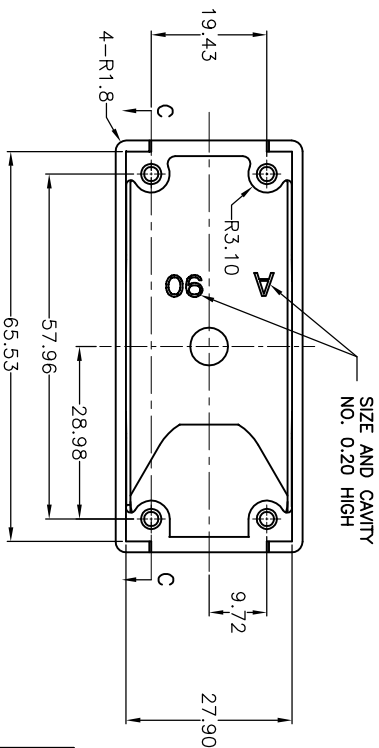

- NOTES:
- 1- STANDARD MATERIAL: 15% ~ 20% GLASS FIBRE POLYCARBONATED, COLOR GREEN/GREY
 - 2- MOULDED PART TO CONFORM TO EDAC STANDARD #110-0211.
 - 3- FILLET RADII TO BE 0.40 UNLESS OTHERWISE SPECIFIED.
 - 4- WARPAGE NOT TO EXCEED 0.40 MAX. AND MUST NOT BOW IN

STANDARD AND METRIC
PLASTIC COVER 90 SIZE

PART NUMBER	MATERIAL	"A" THREAD	REMARKS
516-230-890	GREEN POLYC.	4-40 UNC 2B	
516-230-990	GREY POLYC.	4-40 UNC 2B	

EDAC INC TORONTO, ONTARIO CANADA		THESE DRAWINGS AND SPECIFICATIONS ARE THE PROPERTY OF EDAC INC. AND SHALL NOT BE REPRODUCED, COPIED OR USED AS THE BASIS FOR THE MANUFACTURE OR SALE OF APPARATUS WITHOUT WRITTEN PERMISSION.	
YOUR CONNECTION TO QUALITY & SERVICE			
ACAD REFERENCE NO.	516-230-890	DRAWING REDRAWN, NOTES & TOLERANCES UPDATED N.SONDH NOV. 25/16②	ISSUE NUMBER
DRAWN: C.B	DATE: NOV. 17/2016		2
CHECKED:	DATE:		
SCALE: (IN C.A.D. 1:1)	SHEET 1 OF 2		
DRAWING NUMBER	516-230-890		

THIS IS A C.A.D. GENERATED DRAWING
DO NOT MAKE MANUAL REVISIONS TO MASTER.

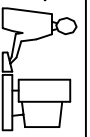

* UNLESS OTHERWISE SPECIFIED TOLERANCES ON DECIMAL IS:		ISSUE NUMBER
UNIT: MM		ORIGINAL ①
DIM: X	TOL: ±0.75	SEE SHEET 1
X.XX	±0.20	N.SONDH NOV. 25/16②
XXX	±0.10	

SANDBLAST FINISH
(REFERENCE SAMPLES)

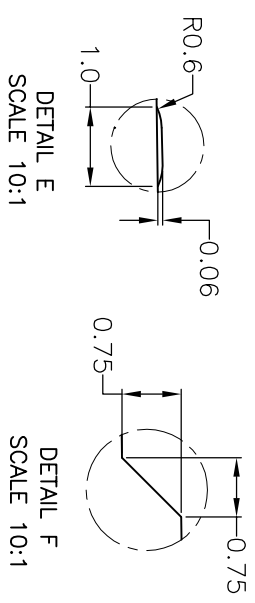
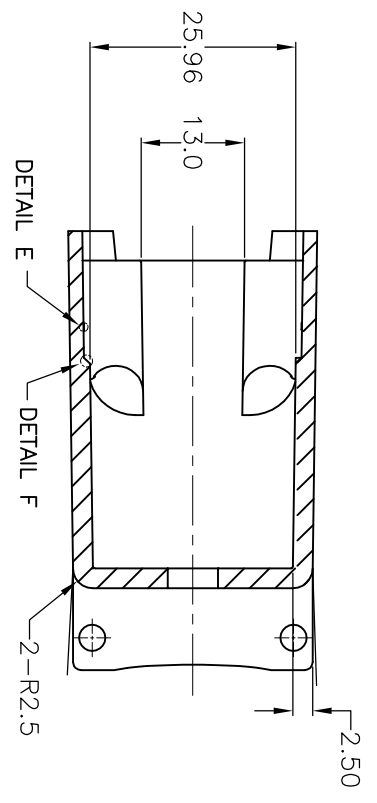
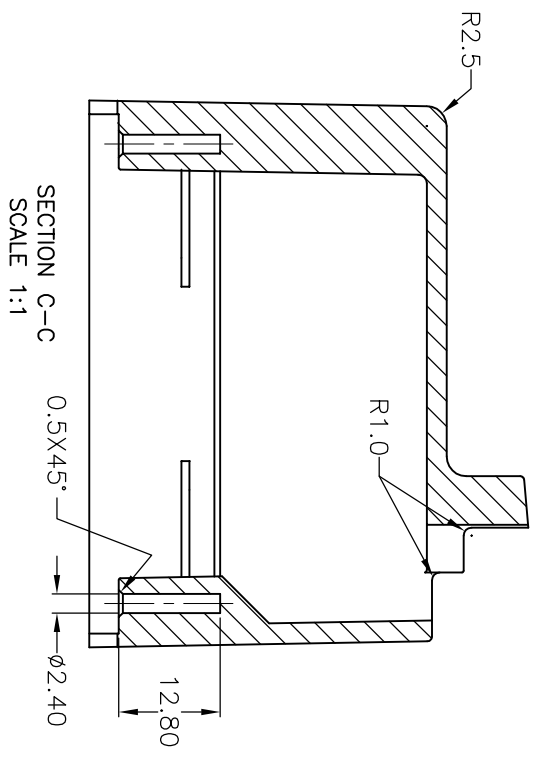
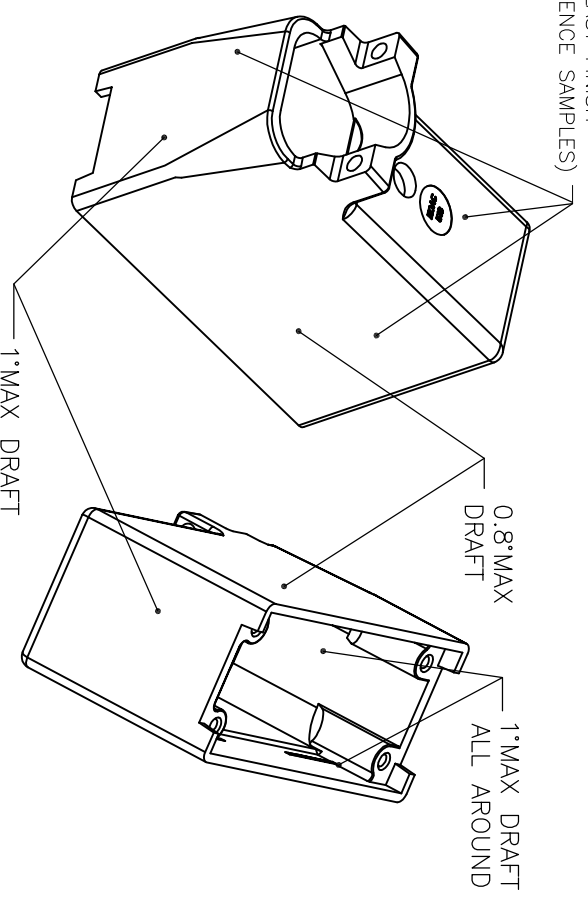

SECTION B-B
SCALE 1:1

STANDARD AND METRIC
PLASTIC COVER 90 SIZE

EDAC INC
TORONTO, ONTARIO
CANADA
YOUR CONNECTION TO QUALITY & SERVICE

THESE DRAWINGS AND SPECIFICATIONS
ARE THE PROPERTY OF EDAC INC. AND
SHALL NOT BE REPRODUCED, COPIED
OR USED AS THE BASIS FOR THE
MANUFACTURE OR SALE OF APPARATUS
WITHOUT WRITTEN PERMISSION.

ACAD REFERENCE NO.	516-230-890
DRAWN: C.B	DATE: NOV.17/2016
CHECKED:	DATE:
SCALE: (IN C.A.D. 1:1)	SHEET 2 OF 2
DRAWING NUMBER	ISSUE
516-230-890	2