

TOLERANCE UNLESS OTHERWISE SPECIFIED	
.X	±0.15
.XX	±0.10

THIS IS A C.A.D. GENERATED DRAWING
DO NOT MAKE MANUAL REVISIONS TO MASTER.

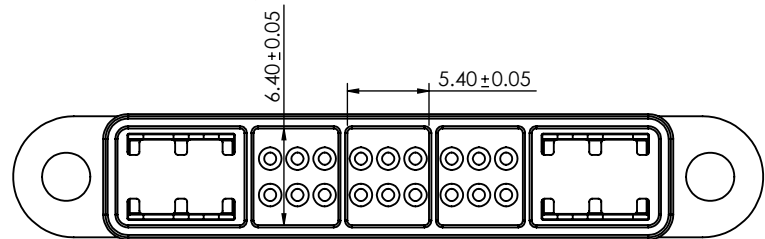

ISSUE NUMBER	
ORIGINAL	①
ADD NOTE 8 & 9	
P.M.	AUG. 12/2023 ②

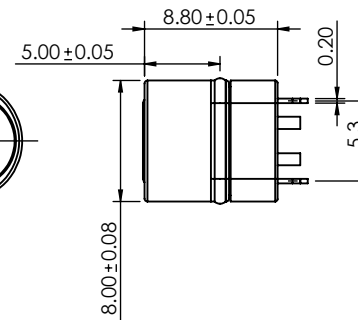
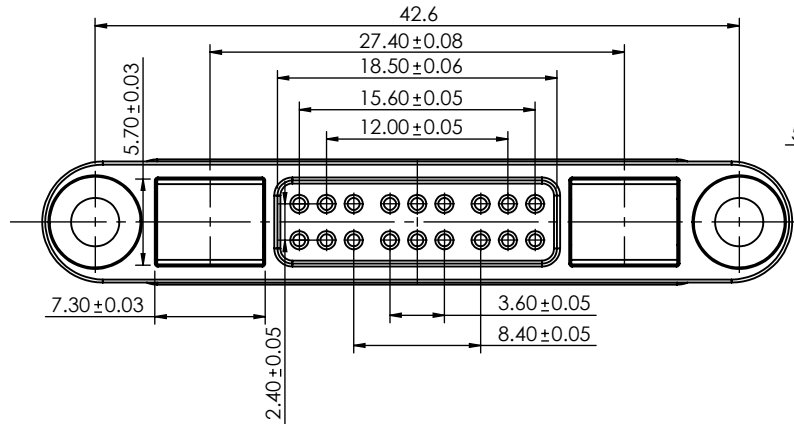
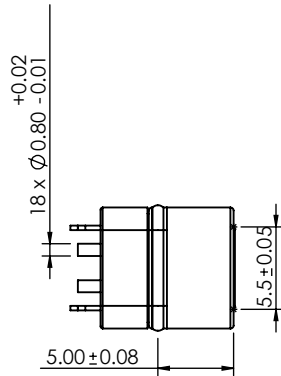
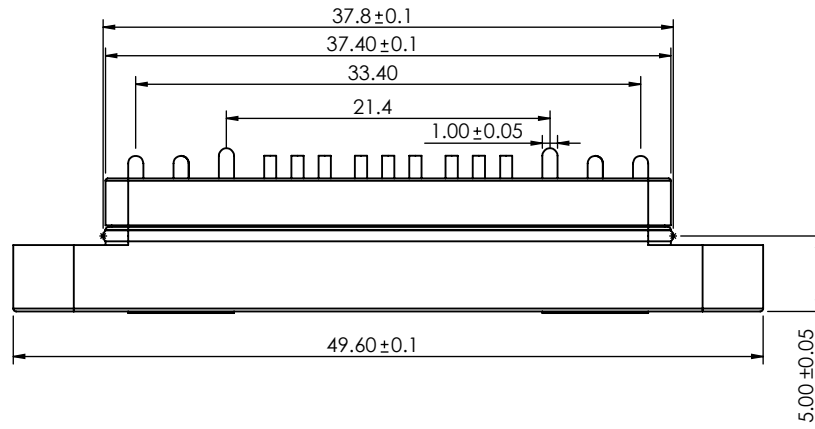

SPECIFICATION:

1- MATERIAL:
CONTACT PLATING: BRASS GOLD FLASH PLATING ALL OVER
NICKEL UNDERPLATING

SPRING: SUS
HOUSING : PA46 BLACK
MAGNET : N52

2- ELECTRICAL:
3- RATED VOLTAGE (PER CONTACT): 12V
4- RATED CURRENT (PER CONTACT): 2A
5- RECOMMENDED WORKING STROKE & FORCE:

STROKE 0.8MM (PER CONTACT): 60gf MAX

6- MECHANICAL LIFE:
0.8mm(MECHANICAL LIFE): 10,000 CYCLES MIN
7- WORKING TEMPERATURE RANGE: -30°C~+85°C

8- RECOMMENDED SOLDERING PROCESS ARE SELECTIVE
SOLDERING OR MANUAL SOLDERING. OTHER FORMS OF
SOLDERING SUCH AS WAVE SOLDER OR REFLOW SOLDER
ARE NOT RECOMMENDED AND CAN POTENTIALLY CAUSE
DEMAGNETIZATION OF MAGNET IN THE CONNECTOR

9- MATING WITH: 686A1821F20111E

MAGNETIC SPRING LOADED CONNECTOR,
18POS, MALE

ACAD REFERENCE NO.:	685A1821220113Q	UNIT: MM
DRAWN:	J.L.	DATE: 8/12/2023
CHECKED:	R.S.M	DATE: 8/12/2023
SCALE:	(IN CAD 1:1)	SHEET 1 OF 1
DRAWING NUMBER:	685A1821220113Q	ISSUE
PART NUMBER:	685A1821220113Q	2



THIS SERIES FULLY CONFORMS TO
THE EUROPEAN UNION DIRECTIVES
2011/65/EU FOR RoHS COMPLIANCY.



YOUR CONNECTION TO QUALITY & SERVICE

EDAC INC
TORONTO, ONTARIO
CANADA

THESE DRAWINGS AND SPECIFICATIONS
ARE THE PROPERTY OF EDAC INC., AND
SHALL NOT BE REPRODUCED, OR COPIED
OR USED AS THE BASIS FOR THE
MANUFACTURE OR SALE OF APPARATUS
WITHOUT WRITTEN PERMISSION.