

TOLERANCE UNLESS OTHERWISE SPECIFIED	
.X	±0.25
.XX	±0.13
.XXX	±0.05

THIS IS A C.A.D. GENERATED DRAWING
DO NOT MAKE MANUAL REVISIONS TO MASTER.

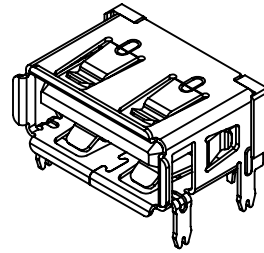

ISSUE NUMBER	
ORIGINAL	①

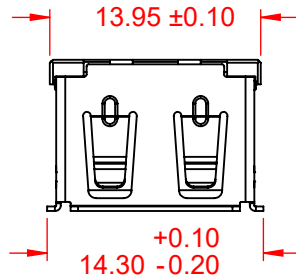

NOTES:

MATERIAL
SHELL: BRASS T=0.30mm
SHELL PLATING: 50µ" MIN. NICKEL PLATED
TERMINAL: PHOSPHOR BRONZE T=0.25 ±0.02mm
TERMINAL PLATING: 3µ" GOLD PLATED ON CONTACT AREA
 100µ" MIN. TIN PLATED ON SOLDER TAILS,
 50µ" MIN NICKEL UNDERPLATED OVERALL

HOUSING: PA66, UL94V-0, WHITE

ELECTRICAL:
RATED VOLTAGE: 30V
RATED CURRENT: 2.0AMP AT 250V AC
INSULATION RESISTANCE: 1000MΩ MIN. 500V DC
CONTACT RESISTANCE: 30mΩ MAX.
DIELECTRIC WITHSTANDING VOLTAGE: 500V AC
TEMPERATURE RANGE: -40°C TO +85°C

MECHANICAL:
INSERTION FORCE: 6 TO 25N MAX.
EXTRACTION FORCE: 10 TO 25N (BEFORE THE TEST)
 8 TO 25N (AFTER THE TEST)
DURABILITY: 30000 CYCLES
SALT SPRAY TEST: 24H

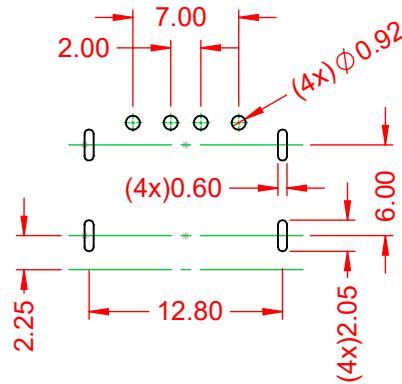
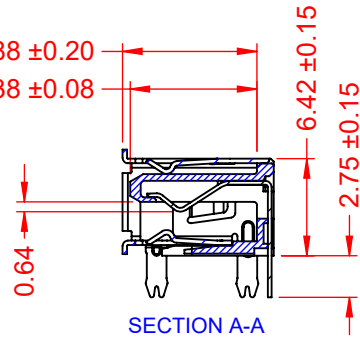
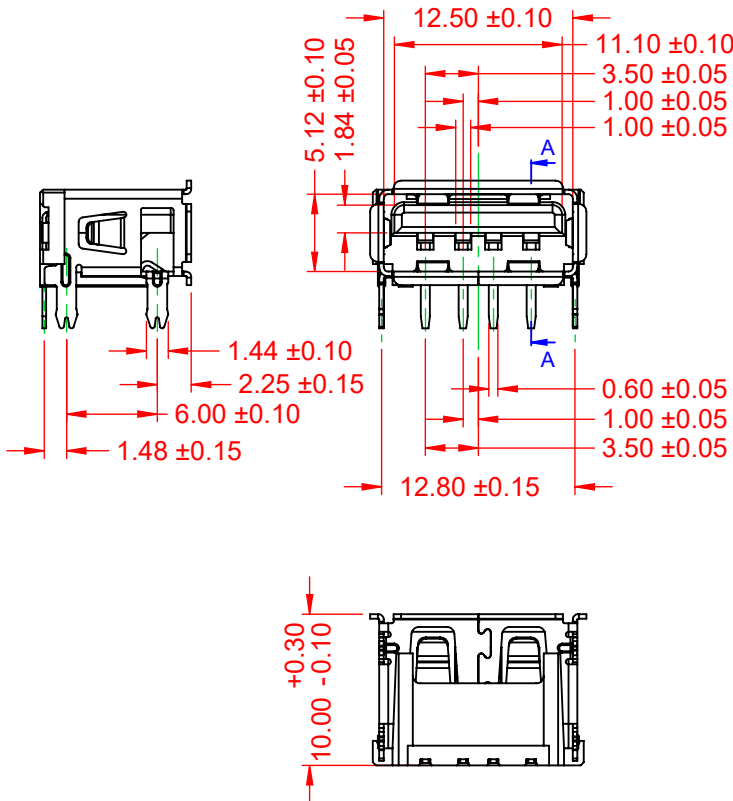

RECOMMENDED P.C.B LAYOUT (TOP VIEW)
P.C.B THICKNESS = 1.60mm (TOLERANCE = ±0.05)

690 SHORT BODY USB TYPE-A RECEPTACLE RIGHT ANGLE PCB		ACAD REFERENCE NO.: 690A104-124-470	
		DRAWN: P.M.	DATE: DEC 17/2020
EDAC EDAC INC TORONTO, ONTARIO CANADA YOUR CONNECTION TO QUALITY & SERVICE		CHECKED: C.B.	DATE: DEC 17/2020
		SCALE: 2:1	SHEET 1 OF 1
DRAWING NUMBER: 690A104-124-470			ISSUE
PART NUMBER: 690A104-124-470			1



THIS SERIES FULLY CONFORMS TO
THE EUROPEAN UNION DIRECTIVES
2011/65/EU FOR RoHS COMPLIANCY.

THESE DRAWINGS AND SPECIFICATIONS
ARE THE PROPERTY OF EDAC INC., AND
SHALL NOT BE REPRODUCED, OR COPIED
OR USED AS THE BASIS FOR THE
MANUFACTURE OR SALE OF APPARATUS
WITHOUT WRITTEN PERMISSION.