

TOLERANCE UNLESS OTHERWISE SPECIFIED	
.X	±0.30
.XX	±0.20
.XXX	±0.10

THIS IS A C.A.D. GENERATED DRAWING
DO NOT MAKE MANUAL REVISIONS TO MASTER.

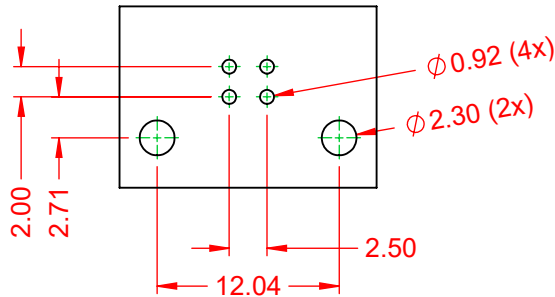

ISSUE NUMBER	
ORIGINAL	①

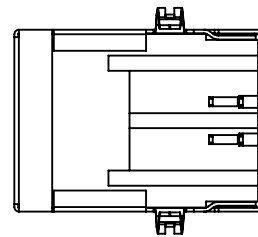
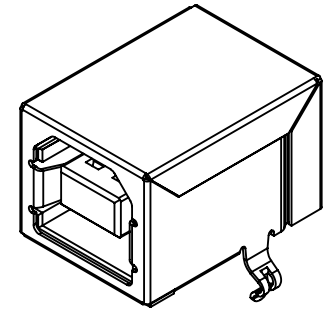
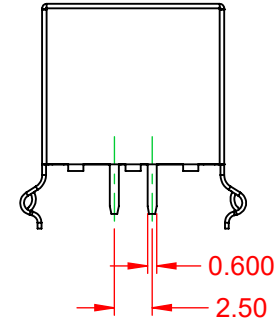
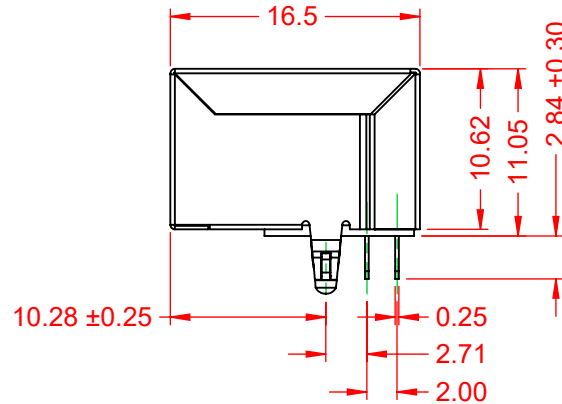
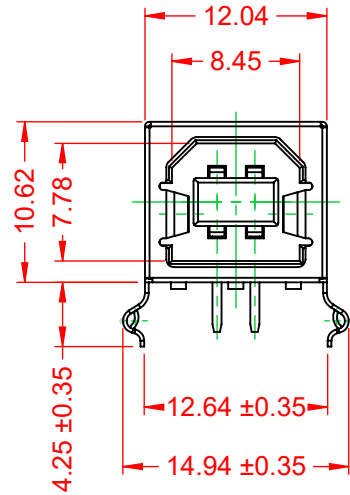

RECOMMENDED P.C.B HOLE LAYOUT
TOP VIEW (TOLERANCE:±0.10)

NOTE:

ELECTRICAL SPECIFICATIONS:

- VOLTAGE RATING: 30V MAX.
- CURRENT RATING: 1.5A
- CONTACT RESISTANCE: 30mΩ MAX.
- INSULATOR RESISTANCE: 1000MΩ min.
- DIELECTRIC WITHSTANDING VOLTAGE: 500V AC / 60s
- OPERATING TEMPERATURE: -20°C ~ 60°C

MATERIAL & FINISH:

- SHELL: COPPER ALLOY, NICKEL PLATED
- HOUSING: LCP, BLACK IN COLOUR, UL94V-0
- CONTACTS: COPPER ALLOY, 15µ" GOLD PLATED



THIS SERIES FULLY CONFORMS TO
THE EUROPEAN UNION DIRECTIVES
2011/65/EU FOR RoHS COMPLIANCY.



YOUR CONNECTION TO QUALITY & SERVICE

EDAC INC
TORONTO, ONTARIO
CANADA

THESE DRAWINGS AND SPECIFICATIONS
ARE THE PROPERTY OF EDAC INC., AND
SHALL NOT BE REPRODUCED, OR COPIED
OR USED AS THE BASIS FOR THE
MANUFACTURE OR SALE OF APPARATUS
WITHOUT WRITTEN PERMISSION.

690 SERIES RECEPTACLES USB 2.0 TYPE-B VERTICAL PCB		ACAD REFERENCE NO.: 690P204-X23-2XX	
DRAWN: C.B	CHECKED:	DATE: December 20, 2020	DATE:
SCALE: 2:1	SHEET 1 OF 1		ISSUE
DRAWING NUMBER: 690P204-X23-2XX	PART NUMBER: 690P204-523-211		1