



161 Alden Road, Units 7 & 8, Markham, Ontario Canada L3R 3W7
 Tel: +1 416 754-3322 Fax: +1 416-754-3299
 Email: support@edac.net http://www.edac.net
ENGINEERING CHANGE NOTICE

Originator:	Wenyu Qin	Date:	Document Number
Phone No.	416-754-3322	March 24, 2026	ECN20260324-00
Email Address:	wqin@edacgroup.net	Revision Number	SHEET
Department	Quality	1	5

CHANGE TYPE:

CLASS I Customer notification and approval required prior to implementation
 CLASS II Customer notification only, no approval required
 CLASS III No customer notification required

REASON OF CHANGE
 Specification Update

DESCRIPTION OF CHANGE:
 Update the IP rating of the following parts from IP67 to IP68:
 --A01-W08-221-450
 --A00-W08-261-458
 For detailed change information, please refer to Pages 2 and 4.

IMPLEMENTATION: 3/23/2026

PARTIES AFFECTED

<input checked="" type="checkbox"/> Customer	<input type="checkbox"/> NORCOMP	<input checked="" type="checkbox"/> ECA
<input checked="" type="checkbox"/> Distributors	<input type="checkbox"/> MH	<input checked="" type="checkbox"/> EDG
<input type="checkbox"/> Suppliers	<input checked="" type="checkbox"/> ETW	<input type="checkbox"/> EDAC UK

KEY TARGET DUE DATES IF CHANGE IS APPROVED TO PROCEED (check if applicable and show target dates as known)

<input type="checkbox"/> Submit Quote	_____	<input type="checkbox"/> PPAP from Supplier	_____
<input type="checkbox"/> Prod. Trial Run	_____	<input type="checkbox"/> MRD of Production Parts	_____
<input type="checkbox"/> Run at Rate	_____	<input type="checkbox"/> UL / CSA / RoHS / REACH	_____

ACKNOWLEDGEMENT FOR ECN INITIATION: (OPTIONALS)		STATUS
<input type="checkbox"/> Tooling Rep	_____	APPROVED <input checked="" type="checkbox"/>
<input type="checkbox"/> Mfg Eng Rep	_____	
<input type="checkbox"/> Production Rep	_____	
<input type="checkbox"/> Materials Rep	_____	
<input checked="" type="checkbox"/> Quality Rep	Wenyu Qin	
<input type="checkbox"/> Marketing Rep	Marco Lamanna	CCS CHANGE REQUEST #
<input type="checkbox"/> Facilities Rep	_____	
<input type="checkbox"/> Sales Rep.	Esther Marothy	
<input type="checkbox"/> Product Eng. Rep.	_____	
<input type="checkbox"/> Purchasing Rep	_____	REJECTED

APPROVALS FOR ECN INITIATION (REQUIRED)		Change REJECTED by:
<input checked="" type="checkbox"/> General Manager	Bob Sakitkovski	Vinesh Kamania
<input checked="" type="checkbox"/> Engineering Manager	Ronnie Sta. Monica	
<input checked="" type="checkbox"/> Business Development Manager	Kobie Samuels	
<input checked="" type="checkbox"/> Quality Engineer	Wenyu Qin	Rejected Date:
<input checked="" type="checkbox"/> Engineer	Vinesh Kamania	

KSJ
3-27-26

REVISIONS			
REV.	DESCRIPTION	DATE	BY
1	ORIGINAL	DRAWN DATE	N.S
2	UPDATED GASKET, CLAMP, PACKAGE SCREW NUT, & SEALING NUT	06/10/2025	J.S.M
3	UPDATE IP RATING	03/04/2026	J.S.M

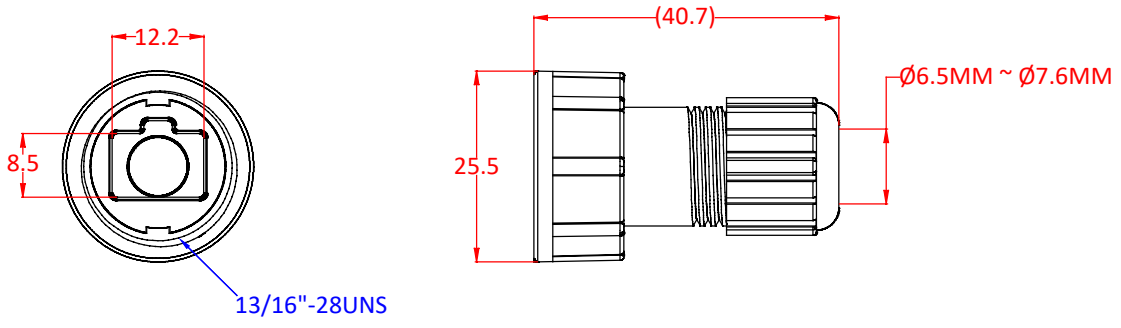
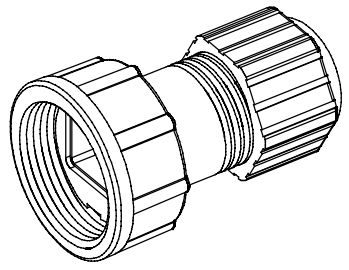
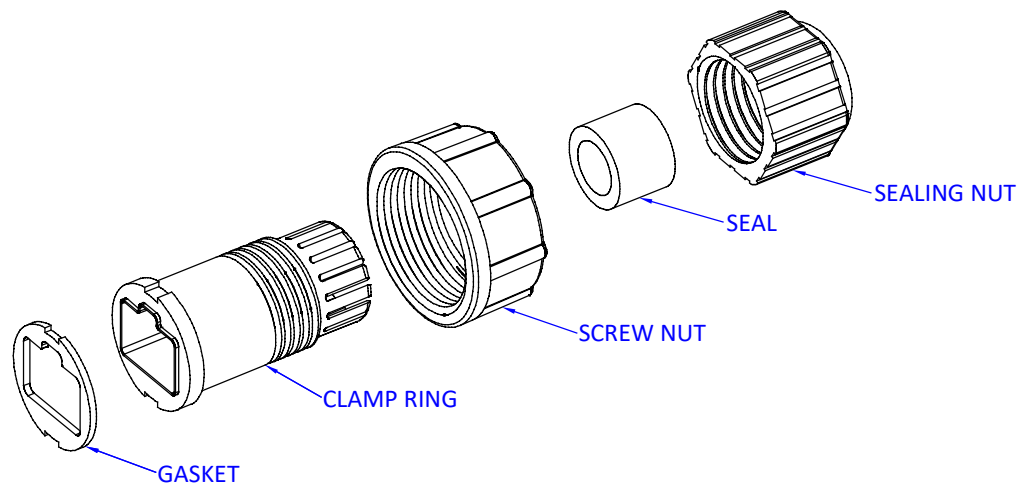

SPECIFICATIONS:

GASKET MATERIAL:	SILICONE
CLAMP RING MATERIAL:	PA66
SCREW NUT MATERIAL:	PA66
SEAL MATERIAL:	SILICONE
SEALING NUT MATERIAL:	PA66
IP RATING:	IP68
PACKAGING TYPE:	TRAY



 RoHS COMPLIANT	THESE DRAWINGS AND SPECIFICATIONS ARE THE PROPERTY OF EDAC, AND SHALL NOT BE REPRODUCED, OR COPIED OR USED AS THE BASIS FOR THE MANUFACTURE OR SALE OF APPARATUS WITHOUT WRITTEN PERMISSION		DRAWN BY N.S	RJ45 PLUG D SIZE SCREW TYPE FIELD INSTALLABLE PLUG			
	DRAWN DATE 07/11/2016	CHECKED BY V.K	CHECK DATE 03/04/2026				
	TOLERANCES		ALL DIMENSIONS AND TOLERANCES IN MM				PART NUMBER A01-W08-221-450
	.X ±0.20 .XX ±0.10 .XXX ±0.05	REF: ED4803					MATERIAL PA66
	SCALE 1:1			SHEET 1 OF 1	REVISION R3		

R2

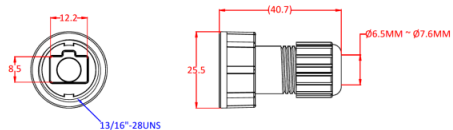
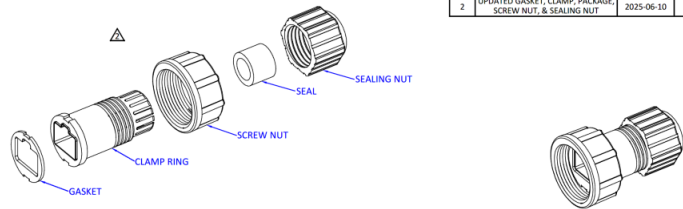

SPECIFICATIONS:

GASKET MATERIAL: SILICONE
 CLAMP RING MATERIAL: PA66
 SCREW NUT MATERIAL: PA66
 SEAL MATERIAL: SILICONE
 SEALING NUT MATERIAL: PA66
 IP RATING: IP67
 PACKAGING TYPE: TRAY

REVISIONS			
REV.	DESCRIPTION	DATE	BY
1	ORIGINAL		N.S
2	UPDATED GASKET, CLAMP, PACKAGE, SCREW NUT, & SEALING NUT	2025-06-10	J.S.M

	DRAWN BY	N.S	R145 PLUG D SIZE SCREW TYPE FIELD INSTALLABLE PLUG			
	DRAWN DATE	2016-07-11				
RoHS COMPLIANT THESE DRAWINGS AND SPECIFICATIONS ARE THE PROPERTY OF EDAC, AND SHALL NOT BE REPRODUCED, OR COPIED OR USED AS THE BASIS FOR THE MANUFACTURE OR SALE OF APPARATUS WITHOUT WRITTEN PERMISSION	CHECKED BY	J.L	PART NUMBER	A01-W08-221-450		
	CHECK DATE	2025-06-10	MATERIAL	PA66	SIZE	A
TOLERANCES	.X	± 0.20	REF: ED4803	REVISION		
	.XX	± 0.10			R2	
	.XXX	± 0.05	SCALE	1:1	SHEET	1 OF 3

R3

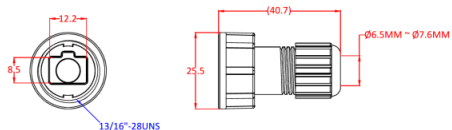
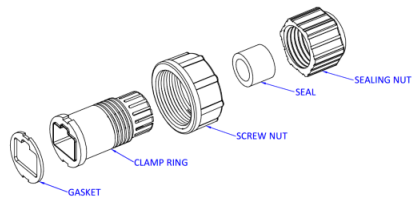

SPECIFICATIONS:

GASKET MATERIAL: SILICONE
 CLAMP RING MATERIAL: PA66
 SCREW NUT MATERIAL: PA66
 SEAL MATERIAL: SILICONE
 SEALING NUT MATERIAL: PA66
 IP RATING: IP68
 PACKAGING TYPE: TRAY

REVISIONS			
REV.	DESCRIPTION	DATE	BY
1	ORIGINAL		N.S
2	UPDATED GASKET, CLAMP, PACKAGE, SCREW NUT, & SEALING NUT	06/10/2025	J.S.M
3	UPDATE IP RATING	03/04/2026	J.S.M

	DRAWN BY	N.S	R145 PLUG D SIZE SCREW TYPE FIELD INSTALLABLE PLUG			
	DRAWN DATE	07/11/2016				
RoHS COMPLIANT THESE DRAWINGS AND SPECIFICATIONS ARE THE PROPERTY OF EDAC, AND SHALL NOT BE REPRODUCED, OR COPIED OR USED AS THE BASIS FOR THE MANUFACTURE OR SALE OF APPARATUS WITHOUT WRITTEN PERMISSION	CHECKED BY	V.K	PART NUMBER	A01-W08-221-450		
	CHECK DATE	03/04/2026	MATERIAL	PA66	SIZE	A
TOLERANCES	.X	± 0.20	REF: ED4803	REVISION		
	.XX	± 0.10			R3	
	.XXX	± 0.05	SCALE	1:1	SHEET	1 OF 1

REVISIONS			
REV.	DESCRIPTION	DATE	BY
1	ORIGINAL	DRAWN DATE	R.S.M
2	UPDATED SHELL, NUT, & SPECIFICATIONS	06/05/2025	J.S.M
3	UPDATE IP RATING	03/04/2026	J.S.M

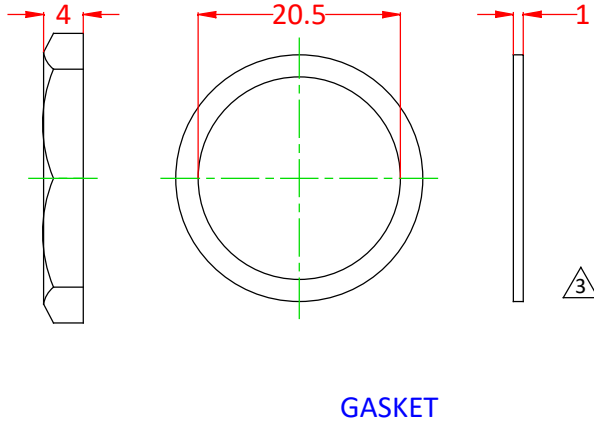
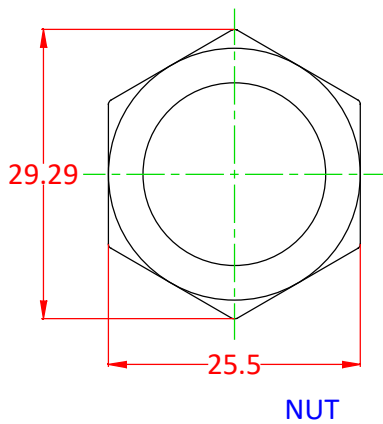
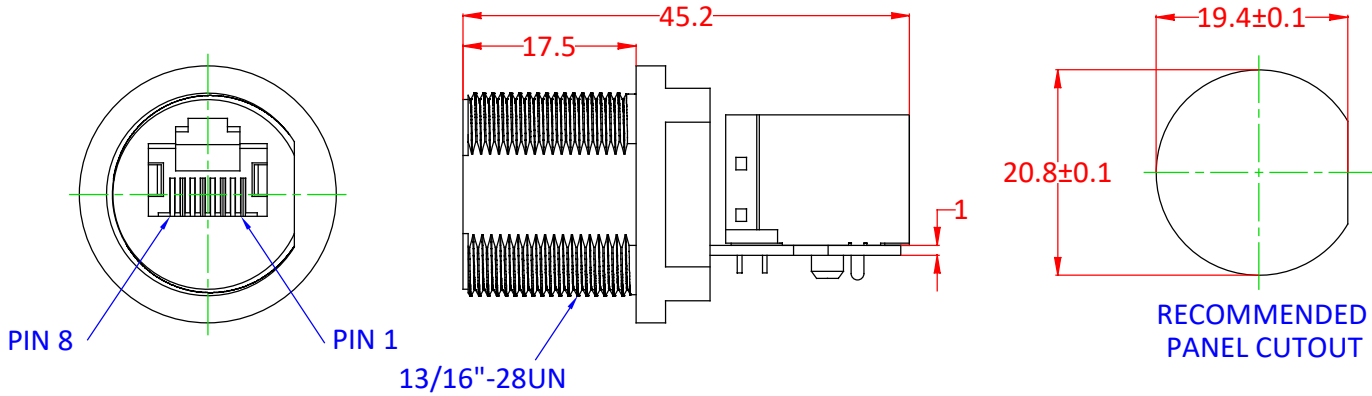

SPECIFICATIONS:

CONTACT MATERIAL:	PHOSPHOR BRONZE
CONTACT PLATING:	GOLD FLASH PLATED
GROUND CONTACT MATERIAL:	STAINLESS STEEL, NICKEL PLATED
HOUSING MATERIAL:	PBT, UL 94V-0, BLACK COLOR
GROUND MATERIAL:	STAINLESS STEEL, NICKEL PLATED
SHELL MATERIAL:	PA66, UL 94V-0, BLACK COLOR
GASKET MATERIAL:	SILICON, GRAY BLACK COLOR
NUT MATERIAL:	PA66
IP RATING:	IP68
PCB MATERIAL:	FR4
CURRENT RATING:	1.5A
VOLTAGE RATING:	125V AC
OPERATING TEMPERATURE:	-40°C~+85°C

	DRAWN BY	R.S.M	WATERPROOF RJ45 MODULAR JACK WITH FILTER					
	DRAWN DATE	05/18/2016						
	CHECKED BY	V.K	PART NUMBER	A00-W08-261-458				
	CHECK DATE	03/04/2026	MATERIAL	PBT	SIZE	A		
RoHS COMPLIANT	TOLERANCES		ALL DIMENSIONS AND TOLERANCES IN MM		REF: ED4690		REVISION	
	.X	±0.20			SCALE		R3	
	.XX	±0.10					1:1	SHEET
	.XXX	±0.05	1	OF	1			

R2

REVISIONS			
REV.	DESCRIPTION	DATE	BY
1	ORIGINAL	DRAWN DATE	R.S.M
2	UPDATED SHELL, NUT, & SPECIFICATIONS	2025-06-11	J.S.M

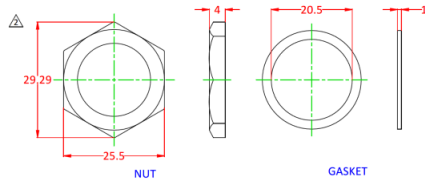
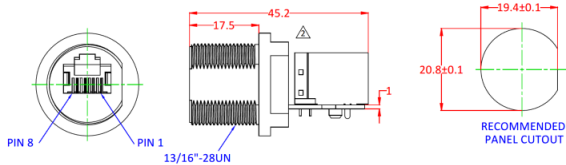

SPECIFICATIONS:

CONTACT MATERIAL: PHOSPHOR BRONZE, GOLD FLASH PLATED
 GROUND CONTACT MATERIAL: STAINLESS STEEL, NICKEL PLATED
 HOUSING MATERIAL: PBT, UL 94V-0, BLACK COLOR
 GROUND MATERIAL: STAINLESS STEEL, NICKEL PLATED
 SHELL MATERIAL: PA66, UL 94V-0, BLACK COLOR
 GASKET MATERIAL: SILICON, GRAY BLACK COLOR
 NUT MATERIAL: PA66
 IP RATING: IP67
 PCB MATERIAL: FR4

CURRENT RATING: 1.5A
 VOLTAGE RATING: 125V AC
 OPERATING TEMPERATURE: -40°C~+85°C

EDAC	DRAWN BY	R.S.M	WATERPROOF RJ45 MODULAR JACK WITH FILTER IP66-IP68 COMPLIANT			
	DRAWN DATE	2016-05-18				
RoHS COMPLIANT	CHECKED BY	J.L	PART NUMBER	ADD-W08-261-458		
	CHECK DATE	2025-06-11	MATERIAL	PBT	SIZE	A
THESE DRAWINGS AND SPECIFICATIONS ARE THE PROPERTY OF EDAC, AND SHALL NOT BE REPRODUCED, OR COPIED OR USED AS THE BASIS FOR THE MANUFACTURE OR SALE OF APPARATUS WITHOUT WRITTEN PERMISSION	TOLERANCES	ALL DIMENSIONS AND TOLERANCES IN MM	REF: ED4690	REVISION R2		
	.X ±0.20 .XX ±0.10 .XXX ±0.05		SCALE	1:1	SHEET	1 OF 1

R3

REVISIONS			
REV.	DESCRIPTION	DATE	BY
1	ORIGINAL	DRAWN DATE	R.S.M
2	UPDATED SHELL, NUT, & SPECIFICATIONS	06/05/2025	J.S.M
3	UPDATE IP RATING	03/04/2026	J.S.M

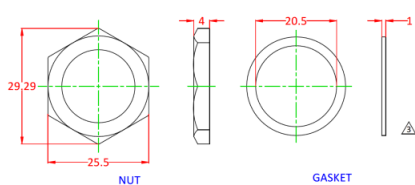
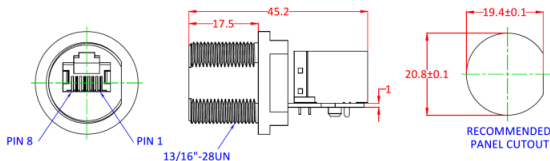

SPECIFICATIONS:

CONTACT MATERIAL: PHOSPHOR BRONZE
 CONTACT PLATING: GOLD FLASH PLATED
 GROUND CONTACT MATERIAL: STAINLESS STEEL, NICKEL PLATED
 HOUSING MATERIAL: PBT, UL 94V-0, BLACK COLOR
 GROUND MATERIAL: STAINLESS STEEL, NICKEL PLATED
 SHELL MATERIAL: PA66, UL 94V-0, BLACK COLOR
 GASKET MATERIAL: SILICON, GRAY BLACK COLOR
 NUT MATERIAL: PA66
 IP RATING: IP68
 PCB MATERIAL: FR4

CURRENT RATING: 1.5A
 VOLTAGE RATING: 125V AC
 OPERATING TEMPERATURE: -40°C~+85°C

EDAC	DRAWN BY	R.S.M	WATERPROOF RJ45 MODULAR JACK WITH FILTER			
	DRAWN DATE	05/18/2016				
RoHS COMPLIANT	CHECKED BY	V.K	PART NUMBER	ADD-W08-261-458		
	CHECK DATE	03/04/2026	MATERIAL	PBT	SIZE	A
THESE DRAWINGS AND SPECIFICATIONS ARE THE PROPERTY OF EDAC, AND SHALL NOT BE REPRODUCED, OR COPIED OR USED AS THE BASIS FOR THE MANUFACTURE OR SALE OF APPARATUS WITHOUT WRITTEN PERMISSION	TOLERANCES	ALL DIMENSIONS AND TOLERANCES IN MM	REF: ED4690	REVISION R3		
	.X ±0.20 .XX ±0.10 .XXX ±0.05		SCALE	1:1	SHEET	1 OF 1