

TOLERANCE UNLESS OTHERWISE SPECIFIED	
.X	±0.25
.XX	±0.13
.XXX	±0.05

THIS IS A C.A.D. GENERATED DRAWING
DO NOT MAKE MANUAL REVISIONS TO MASTER.

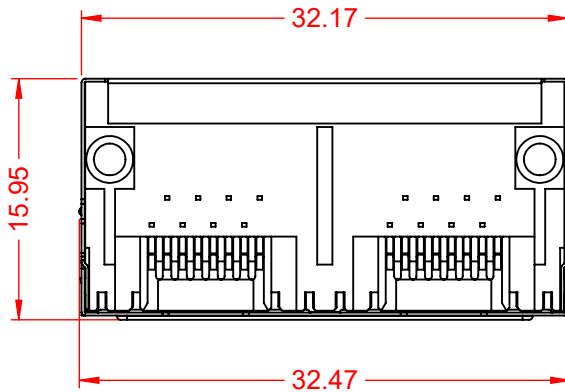

ISSUE NUMBER	
ORIGINAL	①

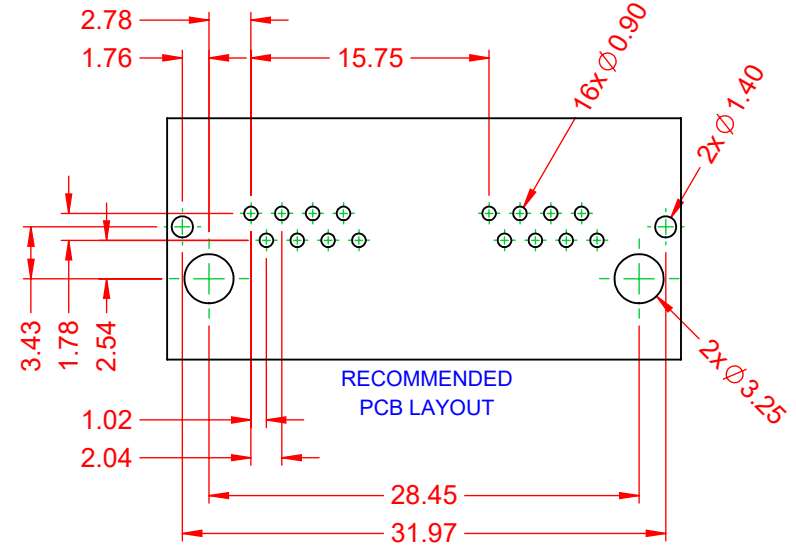
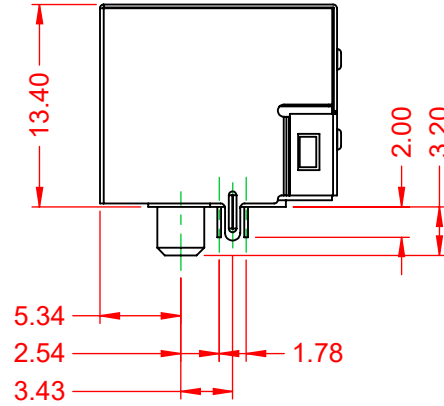
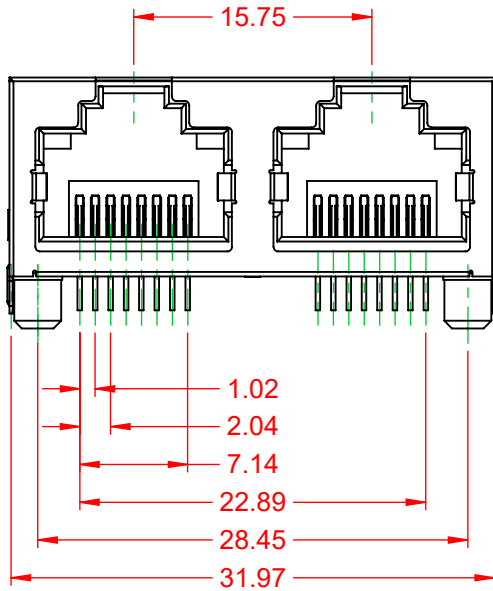

NOTES:

1. MATERIALS:
INSULATOR:
CONTACT:

PBT, BLACK, UL 94V-0
PHOSPHOR BRONZE, SELECT 50µ" GOLD PLATING ON CONTACT AREA
TIN ON TAILS OVER NICKEL

2. VOLTAGE RATING:
3. CURRENT RATING:
4. CONTACT RESISTANCE:
5. INSULATOR RESISTANCE:
5. DIELECTRIC WITHSTANDING:

125 VAC RMS
1.5 AMPS @25°C
20mΩ MAX
1000 MΩ MIN @ 500V DC
1000V AC CONTACT TO CONTACT
OR 1500VDC CONTACT TO SCREEN AND TEST PANEL
@0.5mA 50Hz OR 60Hz 1 MIN

6. DURABILITY:

750 CYCLES MIN

7. MATING/UNMATING FORCE:

30N/3.06KG MAX

8. RETENTION STRENGTH:

50N MIN FOR 60 S +15 S

9. OPERATING TEMP:

-40°C TO +85°C

10. STORAGE TEMP:

-40°C TO +85°C RELATIVE HUMIDITY <80%

11. WAVE SOLDERING TEMP:

260±15°C FOR 5~10 SECONDS

MATES WITH MODULAR PLUG CONFORMING TO FCC PART 68, SUBPART F.



THIS SERIES FULLY CONFORMS TO
THE EUROPEAN UNION DIRECTIVES
2011/65/EU FOR RoHS COMPLIANCY.



YOUR CONNECTION TO QUALITY & SERVICE

EDAC INC
TORONTO, ONTARIO
CANADA

THESE DRAWINGS AND SPECIFICATIONS
ARE THE PROPERTY OF EDAC INC., AND
SHALL NOT BE REPRODUCED, OR COPIED
OR USED AS THE BASIS FOR THE
MANUFACTURE OR SALE OF APPARATUS
WITHOUT WRITTEN PERMISSION.

RJ45, 2 PORT, RIGHT ANGLE PCB MOUNT

ACAD REFERENCE NO.: J6A Assembly	
DRAWN: C.B	DATE: January 13, 2020
CHECKED:	DATE:
SCALE: 2:1	SHEET 1 OF 1
DRAWING NUMBER: J6A Assembly	ISSUE
PART NUMBER: J6A028892P00112	1